

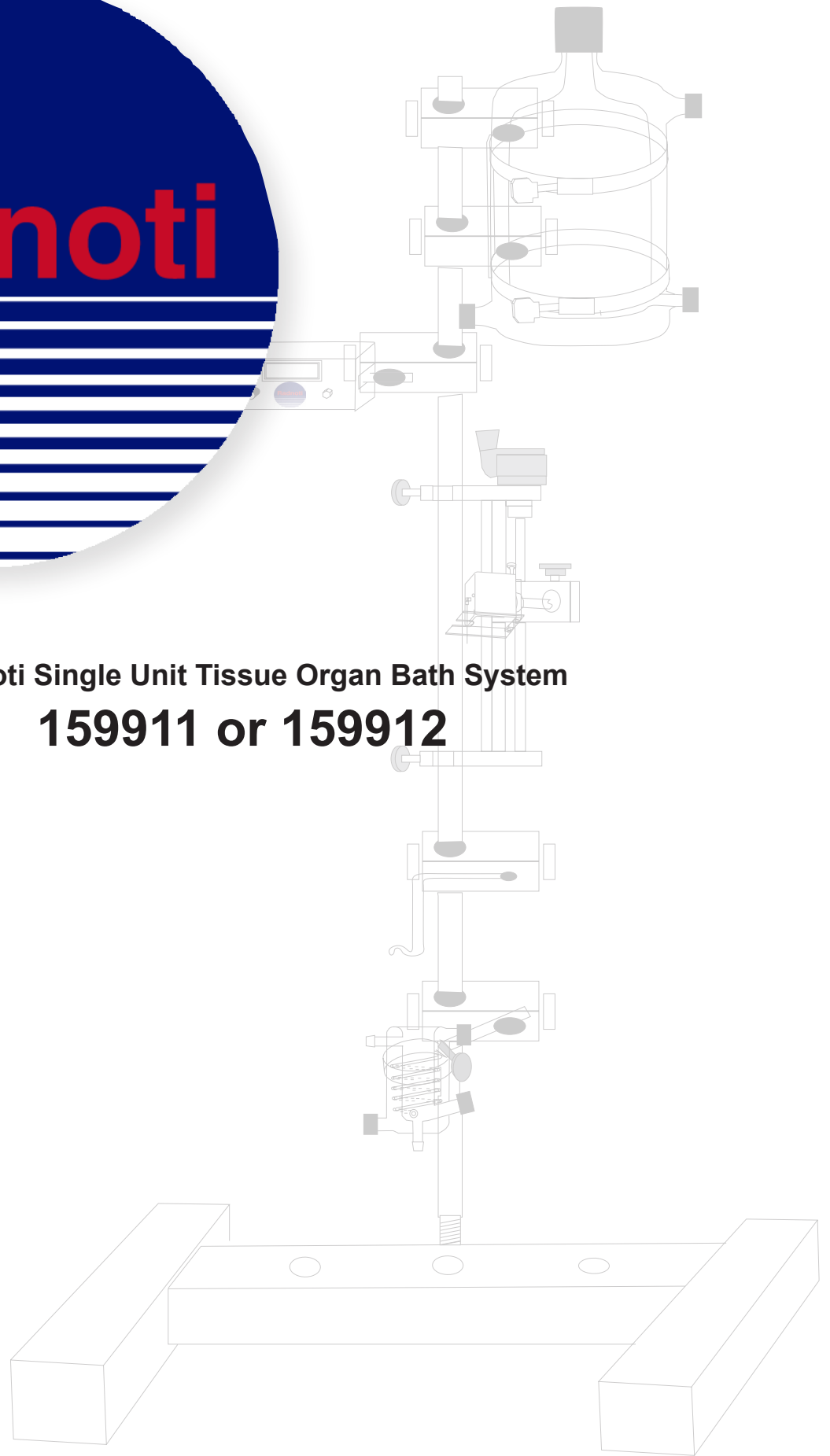

Radnoti Single Unit Tissue Organ Bath System
159911 or 159912

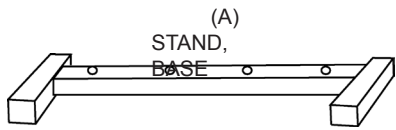

“		#159911	
Description	Qty	Part #	
A Base only, for 1-bar stand	1	159951-1	
B Stand Clamp	2	159952-10	
C Stand Clamp	1	159952-11	
D Stand Clamp Small	2	159952-12	
E Rod 24" Long Stainless Steel	1	159950-24	
F Double Ring Clamp	1	120141-2	
G Single Ring Clamp	1	159953-	
H Tissue Organ Bath Hi-Tech (Specify size)	1	1660-	
I Glass Tissue Hook	1	16017-	
J Oxygenating Bubbler	1	120143-2	
K Water-Jacketed Reservoir	1	120142-2	
L 2 Way Teflon Needle Vavle (Gas)	1	120168	
M Reservoir Filling Funnel	1	120140-A	
N Isometric Force Transducer and Amp	1	159901-A	
O Transducer Positioner	1	159906	
Q.D. Tygon Tubing (Water Jacketed)			
30"	1	120159-30	
72"	2	120159-72	
Inner Tygon Tubing (Perfusate)			
36"	1	120157-36	
72"	1	120157-72	
Gas Tubing			
36"	2	120157-36	
72"	1	120157-72	



(B,C,D)
STAND CLAMP, LARGE

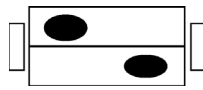

(E)
ROD 24" LONG S.S.

(F)
DOUBLE RING CLAMP

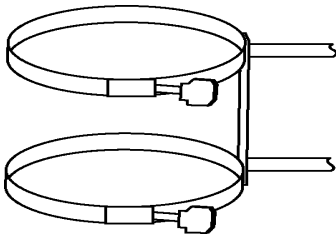

(G)
SINGLE RING CLAMP

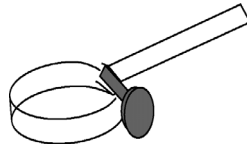

(G)
TISSUE ORGAN BATH

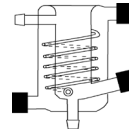

(I)
GLASS TISSUE HOOK

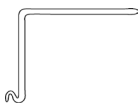

(J)
Oxy Bubbler

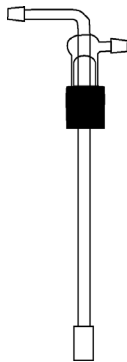

(K)
WATER-JACKET-
ED RESERVOIR

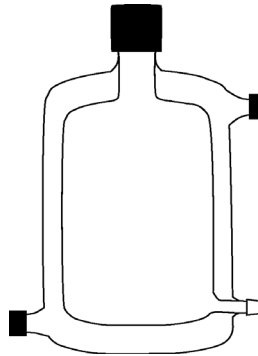

(L)
2 Way Teflon Needle
Vavle (Gas)

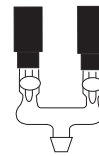

(M)
Reservoir Filling
funnel

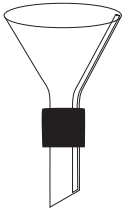

(N)
ISOMETRIC FORCE
TRANSDUCER

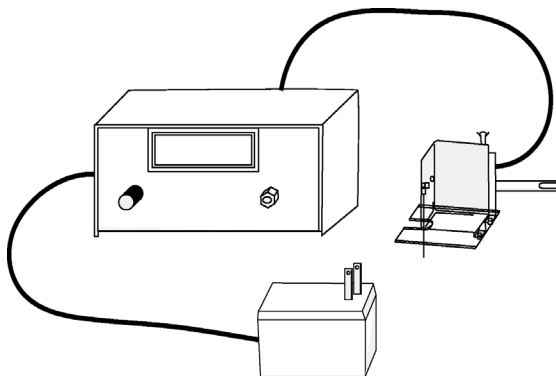

(O)
TRANSDUCER POSITIONER

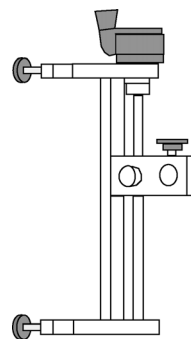

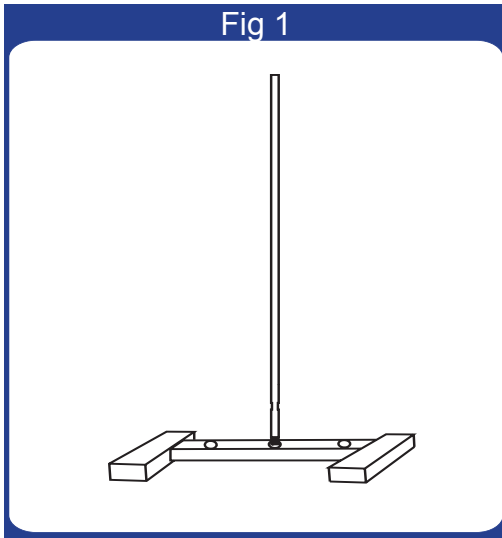

Fig 1

Place Stand Base on a sturdy working surface. Attach the 24" rod into the threaded center hole on the base.

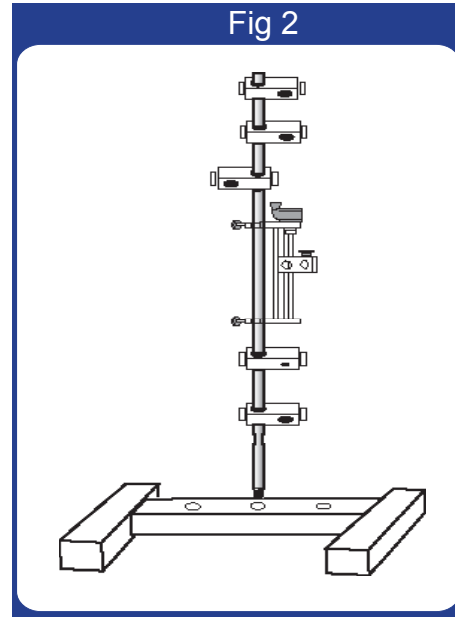

Fig 2

Place the tissue bath in the ring-clamp (f) and tighten, (be careful not to over tighten) and slide the ring-clamp handle in to the Stand Clamp, medium (red) located approximately 8" from the base. See (fig 1). Locate the glass hook and insert it in the Stand Clamp, small (yellow) located approximately 9" from base, Locate the isometric force transducer and slide the transducer head in to the transducer positioner. See (fig 2). Place the double ring-clamp around the reservoir, secure it, and slide in to the Stand Clamps, large (grey) located approximately 20" and 24" from base.

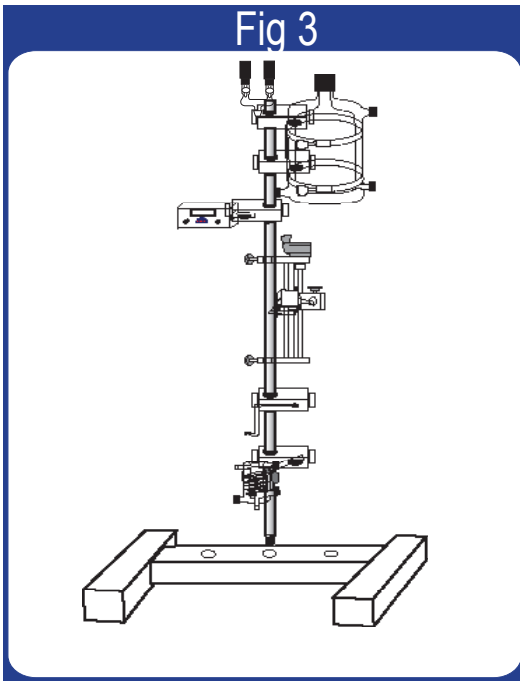
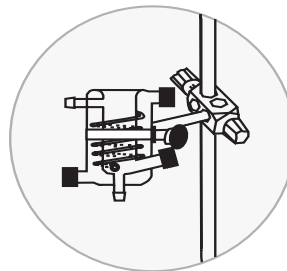
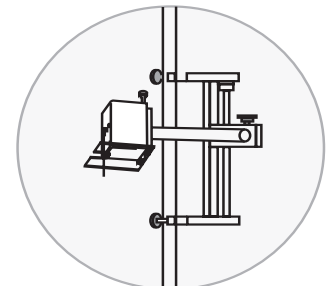

Fig 3

Place one Stand Clamp, medium (red) (C) on the 24" rod approximately 8" from the base. Place one Stand Clamp, small (yellow) (Q) approximately 9" from the base. Slide the transducer positioner (L) above the open sided connector and secure it. Slide a Stand Clamp, medium (red) (C) on the 24" rod approximately 18" from the base. Slide the two Stand Clamps, Large (grey) (B) approximately 20" and 24" from the base.



Open ring-clamp and insert tissue bath. Tighten clamp onto bath. *(be careful not to over tighten).*



Slide transducer head into positioner

Plumbing for Baths

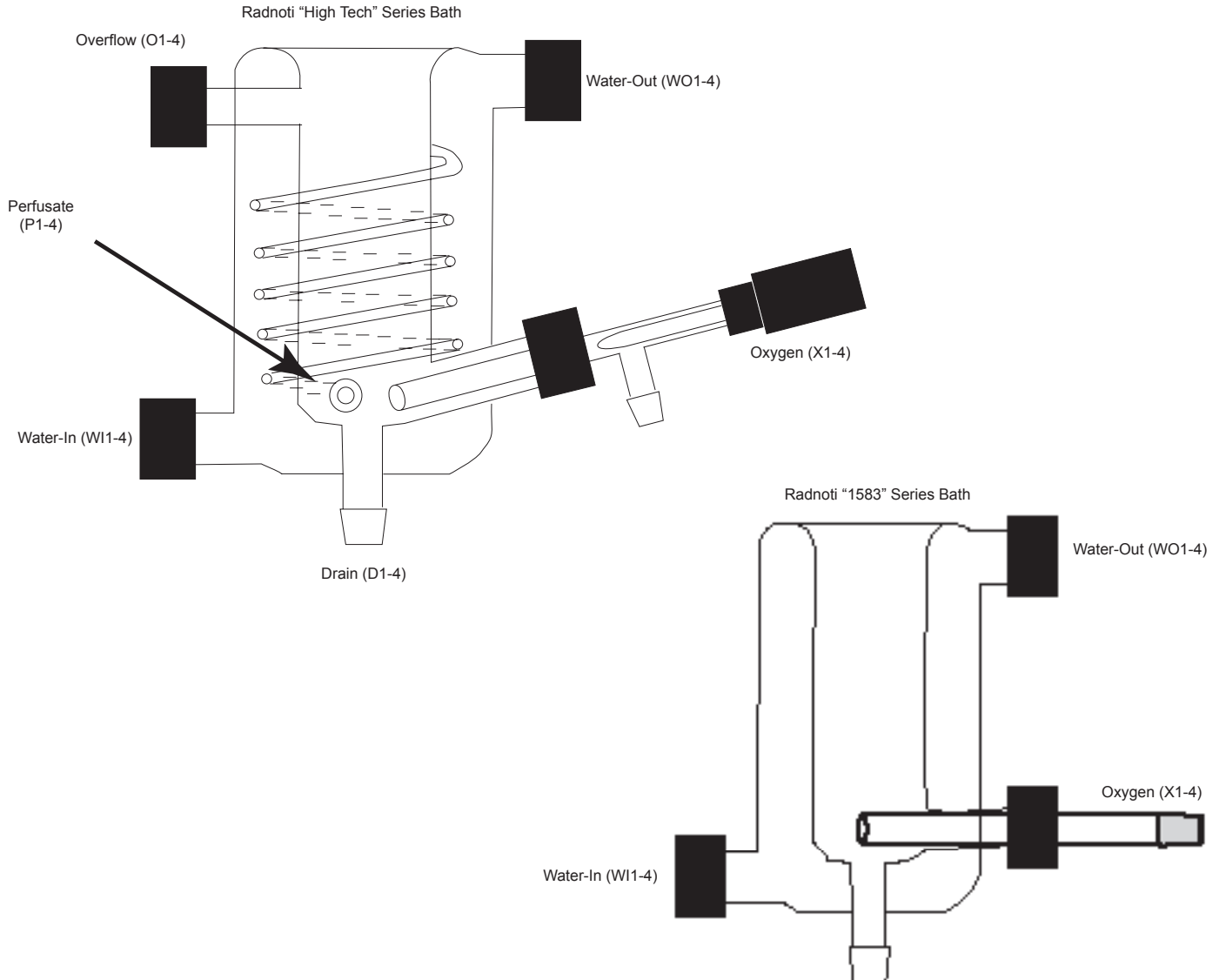

Water-Jacketed Tubing Connection Chart

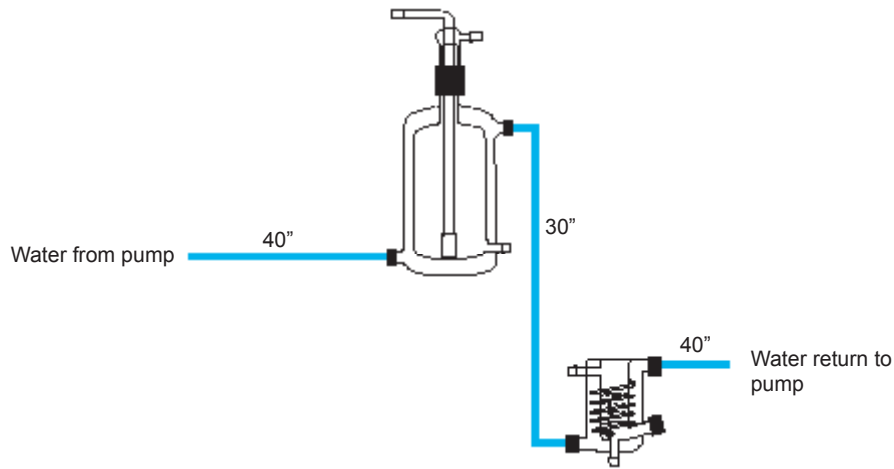

Oxygen Connection Chart

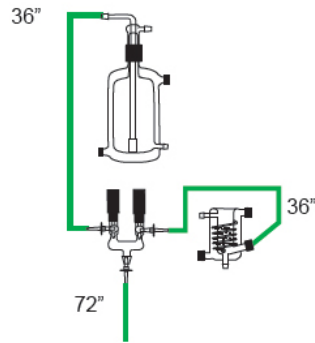

Perfusate Connection Chart

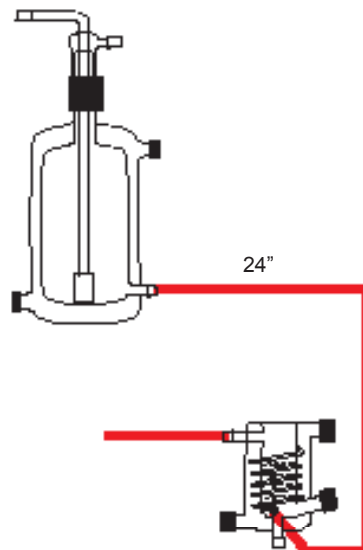

Drain and Overflow Connection Chart

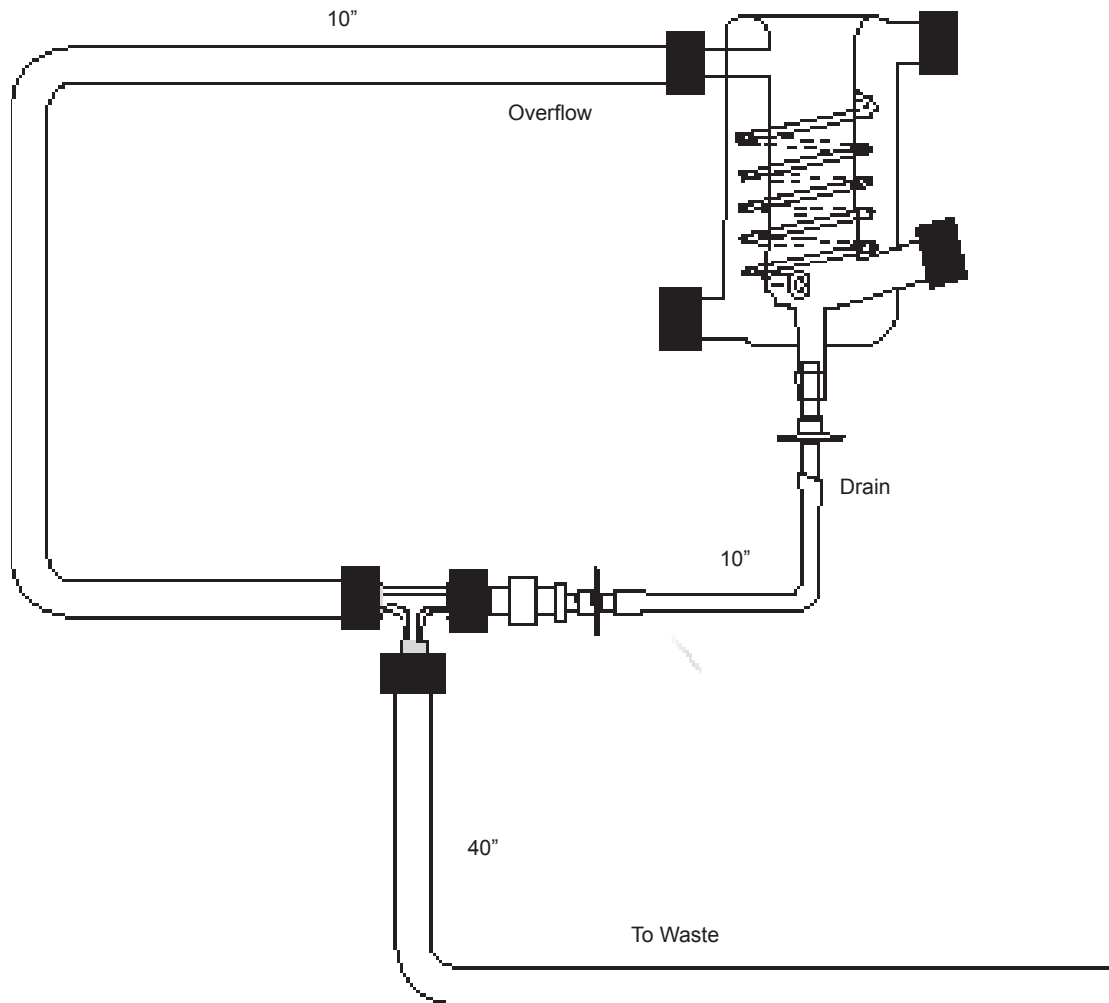

RADNOTI 'QUICK DISCONNECT' INSTRUCTIONS

For Reference only

A	Slide Cap-With hole onto the water line. (Tygon tubing #120159)
B	Push the plastic sleeve insert into the end of the Tygon tubing with the flared end first. (Catalog #120160)
C	Be sure to use 5/16 x 3/16 inch Tygon tubing. (Catalog #120159)
D	<u>MOISTEN TIP OF TYGON TUBING</u> before insertion into the threaded glass.
	CAUTION: To avoid breakage, do not over tighten the screw cap.

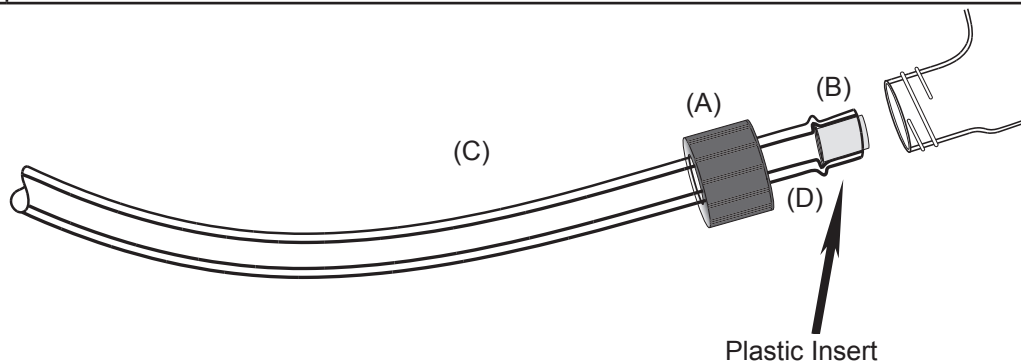

Replacement Part List:

Catalog No.	Description
120160	Plastic sleeve insert, 25/Pkg
120159	Tygon tubing 5/16 x 3/16 ID, 50 ft/min
160196	Drilled cap for W/J.Q.D.

Use of Radnoti 159901A Isometric Force Transducer

This transducer operates on the principle of converting picofarad capacitance changes into an amplified DC output voltage by means of a patented circuit (U.S. Patent Number 4142144). The transducer consists of a stiff beam suspended between two capacitor plates. This forms a differential capacitor. Using this principal, the beam can be exceptionally stiff, approaching the ideal of measuring force without motion. As an example, for a force of 2 grams, the beam deflection is a maximum of only 5 microns in either the 0.2 or 2.0 gram range mode. The linearity is within +1% with a high DC voltage output and freedom from drift.

Transducer Mounting

The transducer comes with an integral short, rigid mounting handle. To obtain maximum advantage of stiff beam characteristics of the transducer, it should be positioned and held in place with hardware that is as rigid as possible such that all the muscle forces are recorded (i.e. captured) and none are lost in extraneous deflections of the mounting hardware. The 159951 series of Radnoti Research Support Stands are the mounting hardware of choice. Their massive, durable construction will not deflect under load. The transducer itself should be positioned such that the output cable at the rear of the transducer ends up on the bottom (see Fig. 1 and 2).

Positioning the Muscle Sample

The transducer has a short tissue mounting rod with a groove that projects from the front (see figure1). One end of a non-stretching string or wire must be formed into a loop and fastened into the groove on the shaft. The other end of the string or wire is subsequently attached to the muscle preparation. The wire or string from the beam must be directed through the slot in the splash shield without the final setup has been completed.

Splash Shield

The transducer is equipped with a transparent, removable plastic shield which helps to prevent buildup of salts (i.e. corrosives) which may otherwise tend to accumulate on the transducer rod and migrate into the transducer circuit (see Fig. 1). In time, this salt buildup can deteriorate performance. The wire or string from the beam must be directed through the slot in the splash shield without touching the edges (see Fig. 1).

GENERAL INFORMATION

Amplifier / Power Supply

- The entire transducer is powered by a 12 volt AC wall transformer (see Fig. 2).
- There is no ON/OFF switch. The unit can remain powered, as shown on the digital meter, for the entire experiment.

Front Panel Controls

a) RANGE SELECTOR

The range selector switch has two positions: 2.0 gram and 20.0 gram (see Fig. 2).

- In the 2.0 gram position, a 2.0 gram force produces a 5 VDC output.
- In the 20.0 gram position, a 20.0 gram force produces a 5 VDC output.

b) OFFSET

The OFFSET control enables the user to set a zero output voltage for any pre-load value (see Fig. 2). It is essentially a "Tare Control" device since it balances out static loads such as the weight of the muscle preparation prior to contraction and the support wire or string.

Internal Controls and Adjustments

On the rear panel of the power supply are three small access holes to the trim ports (see Fig.3). The high and low gain trim ports are used to adjust the range. The right-hand trim port is factory set to deliver 5.0 VDC for 2.0 gram. The center trim port is factory set to deliver 5.0 VDC for 20.0 gram. Either can be adjusted to deliver more or less output as conditions dictate. The OFFSET adjustment trim port is located on the extreme left and has been factory adjusted to center the offset control. It also can be adjusted in situations where the front panel offset control does not have sufficient range. It can be used to correct for static loads equivalent to signals between +0.6v and -1.2v.

Electrical Output

- a) A BNC jack on the rear of the amplifier is provided for output connections (see Fig. 3)
- b) Output voltage is 0 to 5.0 VDC depending upon the position of the range selector switch. *Output impedance is 2 kilo-ohms for direct connection to all recorders.
- c) The transducer is linear to 100% overload (4 or 40 grams, depending on setting).
- d) An internal frequency response jumper is factory set to 1000Hz
The jumper is located inside the chassis next to the trim pots. After unplugging the unit, the jumper can be moved to a second position forward towards the front of the amplifier. This will reduce the frequency response to 10 Hz for situations where signal dampening

Maintenance and Storage

- a) No special precautions are required other than preventing corrosive solutions from entering the space where the output shaft exits the transducer.
- b) When not in use, store in a clean, dry place.

Serial Number

The serial number is located on the Power supply circuit board. Refer to this number in any correspondence.

